

MULTIPIN CONNECTOR FOR REMOVABLE BATTERY

GC/GD SERIES

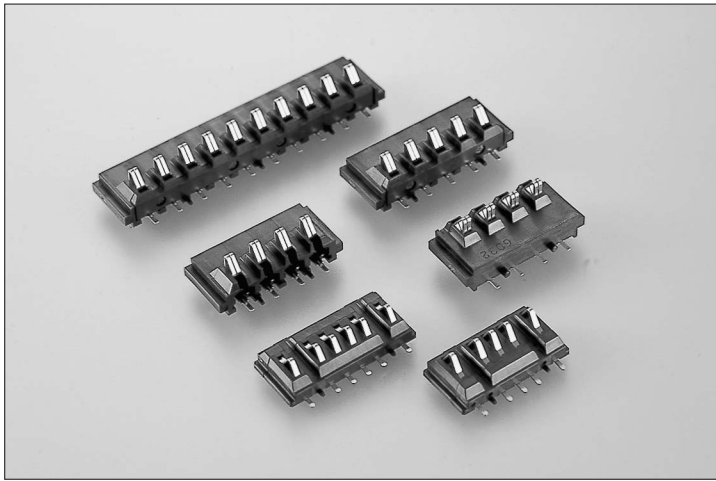



FEATURES

- Stroke displacement of 2.5mm for GC series and 2.3mm for GD series in a miniature connector.
- Contact cleans battery terminal every mating cycle.
- Life is 10,000 cycles for GC series and 5,000 cycles for GD series.
(Nickel plated battery terminal is changed every 1,000 cycles)
- Highly reliable and stable contact design.
- Gold plating (0.3 μ m) for contact reliability.
- 4 variations: Standard type of 5mm pitch (GC11 series)
Reverse type of 5mm pitch (GC02 series)
Standard type of 3mm pitch (GD01 series)
Reverse type of 3mm pitch (GD02 series)
- RoHS compliance

SPECIFICATIONS

- Insulator : Glass-filled Polyamid 6T (UL 94V-0), Black
- Contact material : Copper alloy
- Contact plating :
Contact area ; 0.3 μ m min. Gold over Nickel
Terminal area ; [GC□□-□□-□F]
2 μ m min. Tin copper over Nickel
[GD01-□□-1F]
0.03 μ m min. Gold over Nickel
- Current rating : GC series ; 5A DC per contact(2 contacts max.)
GD series ; 5A DC per contact(2 contacts only at both ends)
- Current voltage : 30V DC
- Contact resistance : 30m Ω max.
- Dielectric withstanding voltage : 650V AC for 1 minute.
- Insulation resistance : 500M Ω min. at 500V DC
- Total contact force : GC series ; 230g \times No. of contacts max.
GD series ; 200g \times No. of contacts max.
- Operating temperature : -55 $^{\circ}$ C to +85 $^{\circ}$ C
- * Specification for Battery electrode : Material ; Nickel
GC series (Finish): Nickel plating 2~4 μ m
GD series (Finish): Gold plating 0.3 μ m min.
over Nickel plating 2~4 μ m

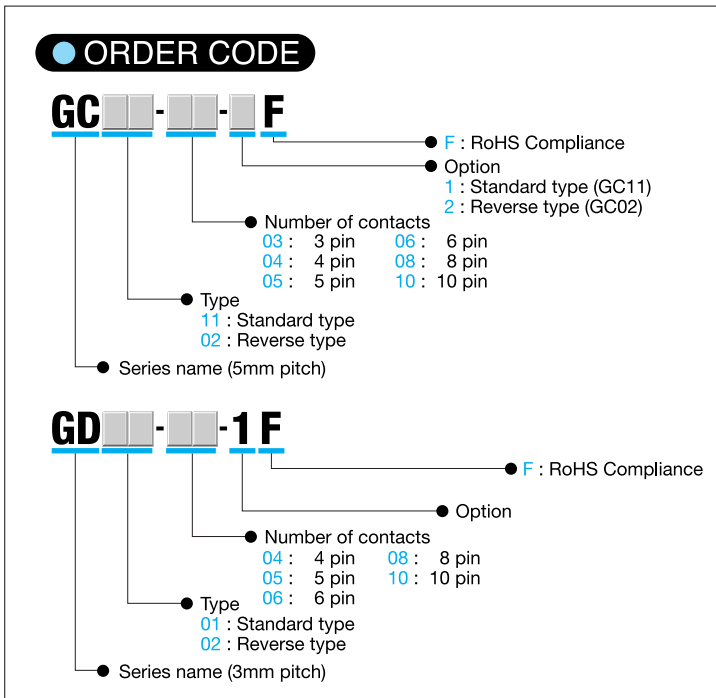

CHARACTERISTICS GC11-□□-1F is shown.

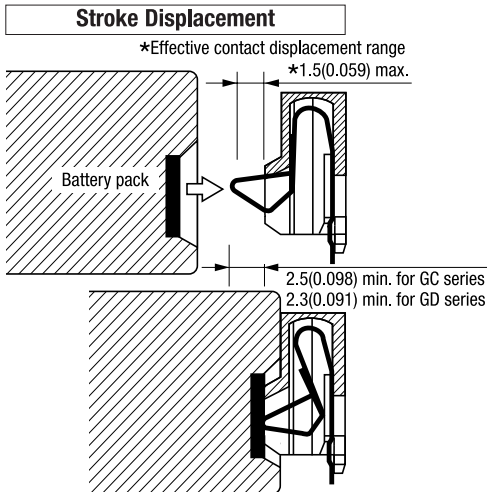

- Contact adjusts to variations in battery pack position.
- Effective contact displacement is 1.5(0.059) max.

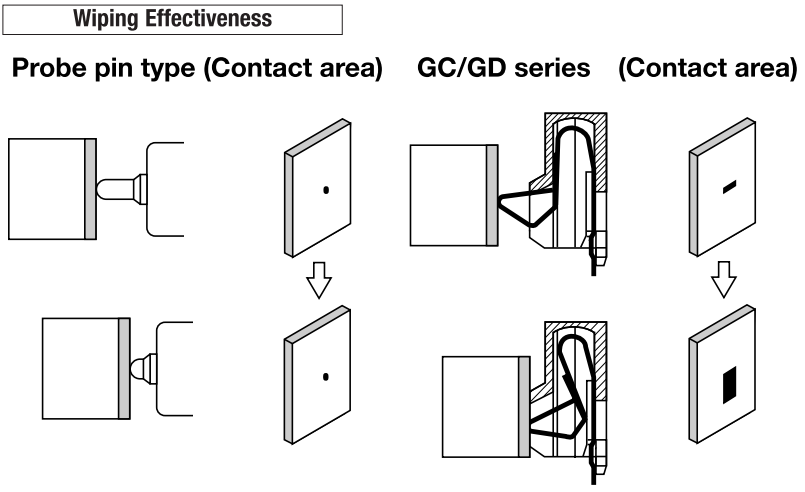

- Probe pin construction does not provide a wiping mechanism which must be provided separately. As shown above, The GC/GD series contacts wipe the battery pack terminals.

GC11-□□-1F (Standard Type)

Unit:mm(inch)

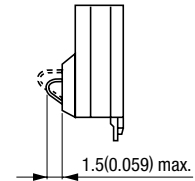
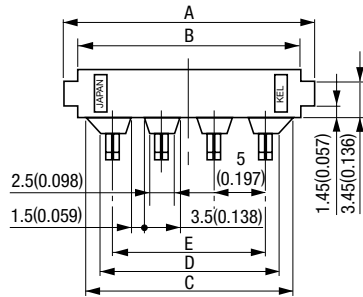
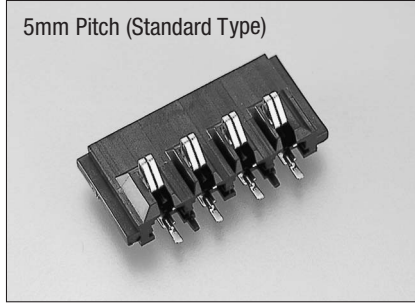

Effective contact displacement range

X-X' Cross Section

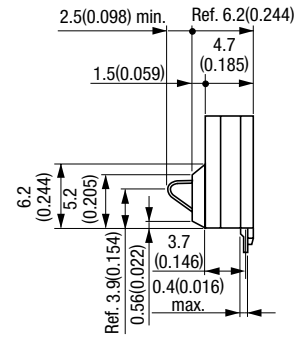
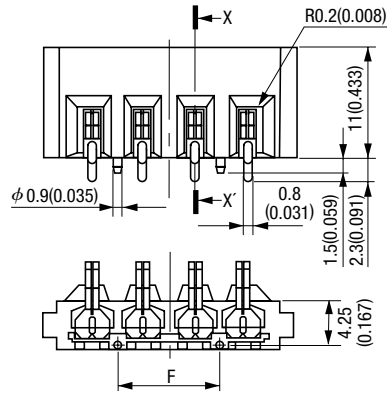
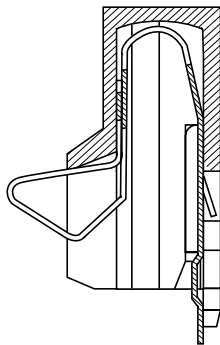

Note: 4 pin connector is shown.

Printed Circuit Board Layout (Component Side View)

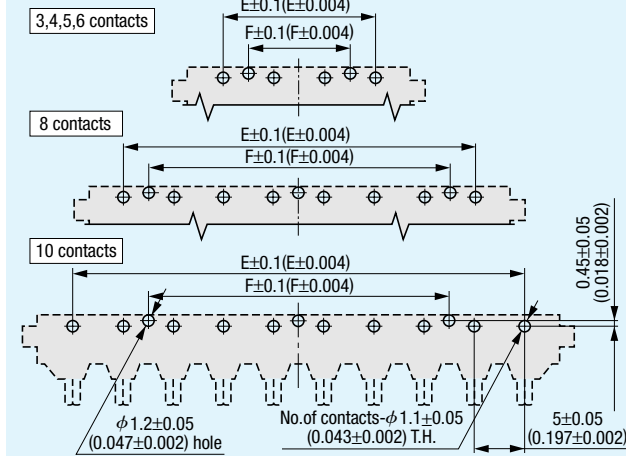

Recommended Dimensions for Battery Terminals

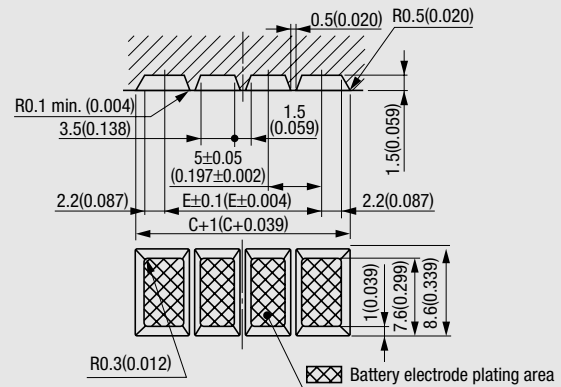

Packaging style
Tray

Product Table / Dimensions

No. of contacts	Part Number	A	B	C	D	E	F	Number of packaging
3	GC11-03-1F	20 (0.787)	17 (0.669)	15.6 (0.614)	13.4 (0.527)	10 (0.394)	5 (0.197)	50
4	GC11-04-1F	25 (0.984)	22 (0.866)	20.6 (0.811)	18.4 (0.724)	15 (0.591)	10 (0.394)	50
5	GC11-05-1F	30 (1.181)	27 (1.063)	25.6 (1.008)	23.4 (0.921)	20 (0.787)	15 (0.591)	50
6	GC11-06-1F	35 (1.378)	32 (1.260)	30.6 (1.205)	28.4 (1.118)	25 (0.984)	20 (0.787)	25
8	GC11-08-1F	45 (1.772)	42 (1.654)	40.6 (1.598)	38.4 (1.512)	35 (1.378)	30 (1.181)	25
10	GC11-10-1F	55 (2.165)	52 (2.047)	50.6 (1.992)	48.4 (1.906)	45 (1.772)	30 (1.181)	25

GC02-□□-2F (Reverse Type)

Unit:mm(inch)

5mm Pitch (Reverse Type)

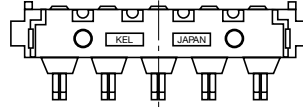
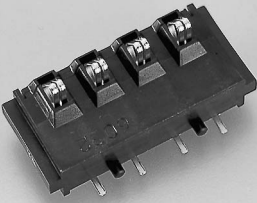

X-X' Cross Section

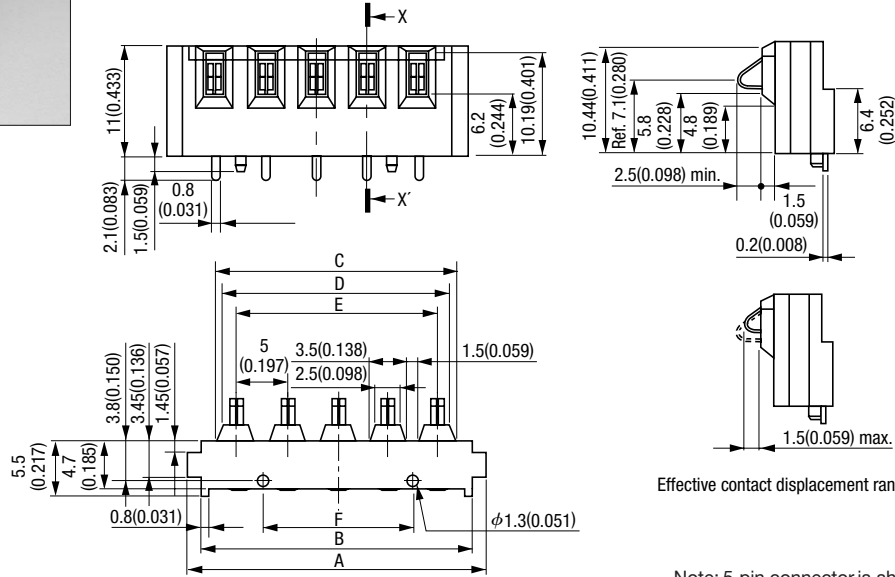
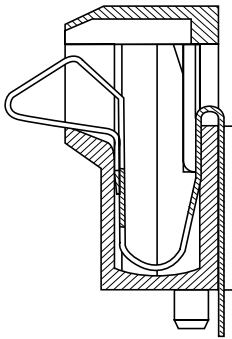

Effective contact displacement range

Note: 5 pin connector is shown.

Printed Circuit Board Layout (Component Side View)

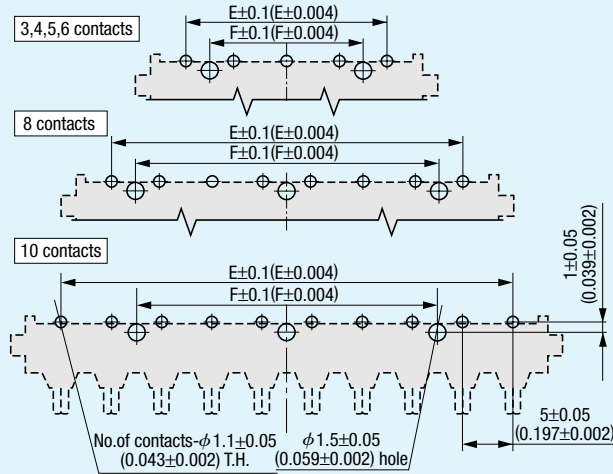

Recommended Dimensions for Battery Terminals

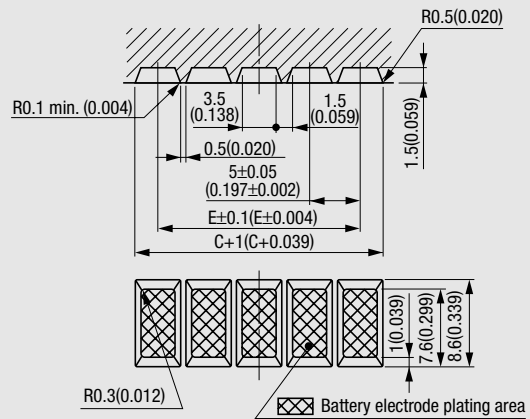

Packaging style
Tray

Product Table / Dimensions

No. of contacts	Part Number	A	B	C	D	E	F	Number of packaging
3	GC02-03-2F	20 (0.787)	17 (0.669)	13.5 (0.531)	12.5 (0.492)	10 (0.394)	5 (0.197)	75
4	GC02-04-2F	25 (0.984)	22 (0.866)	18.5 (0.728)	17.5 (0.689)	15 (0.591)	10 (0.394)	65
5	GC02-05-2F	30 (1.181)	27 (1.063)	23.5 (0.925)	22.5 (0.886)	20 (0.787)	15 (0.591)	50
6	GC02-06-2F	35 (1.378)	32 (1.260)	28.5 (1.122)	27.5 (1.083)	25 (0.984)	20 (0.787)	39
8	GC02-08-2F	45 (1.772)	42 (1.654)	38.5 (1.516)	37.5 (1.476)	35 (1.378)	30 (1.181)	25
10	GC02-10-2F	55 (2.165)	52 (2.047)	48.5 (1.909)	47.5 (1.870)	45 (1.772)	30 (1.181)	25

GD01-□□-1F (Standard Type)

Unit:mm(inch)

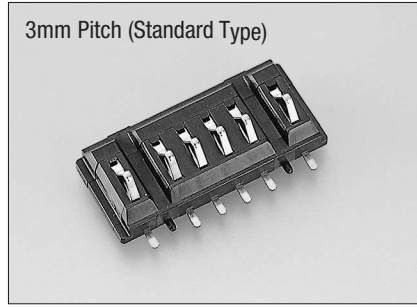

X-X' Cross Section

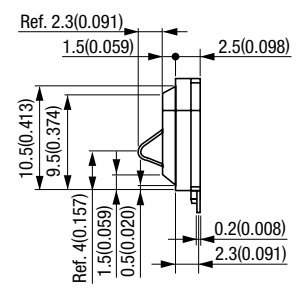
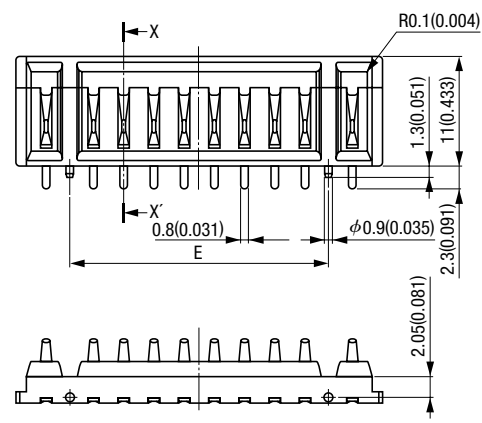
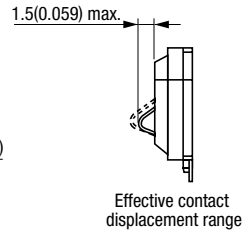
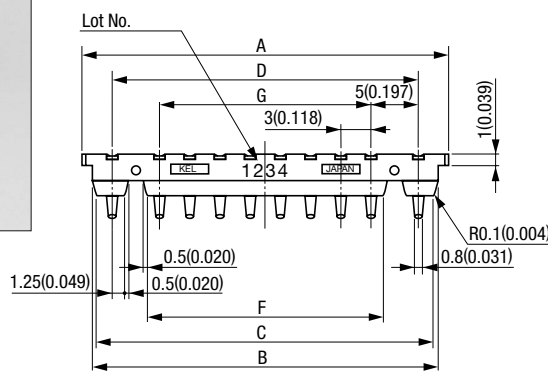
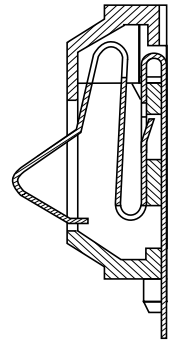

Note: 10 pin connector is shown.

Recommended PCB Layout (Component Side View)

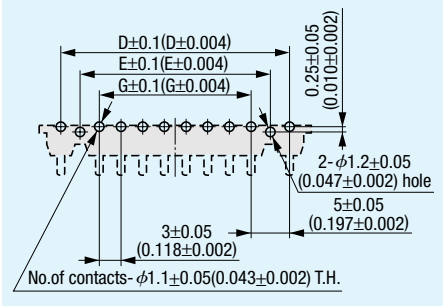

Recommended Dimensions for Battery Terminals

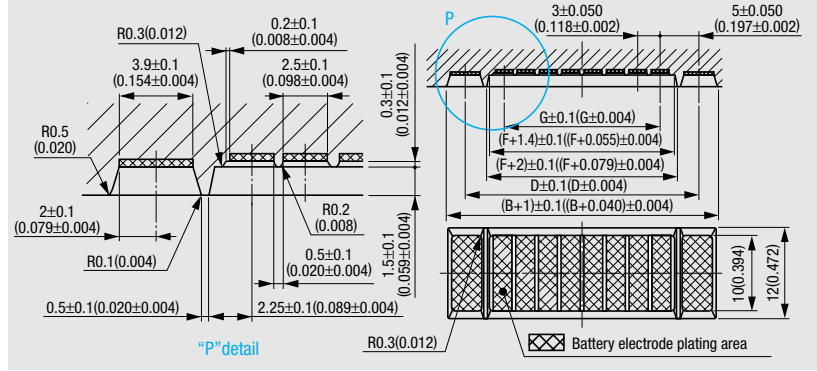

Packaging style
Tray

Product Table / Dimensions

No. of contacts	Part Number	A	B	C	D	E	F	G	Number of packaging
4	GD01-04-1F	19 (0.748)	17 (0.669)	16 (0.630)	13 (0.512)	8 (0.315)	5.5 (0.217)	3 (0.118)	90
5	GD01-05-1F	22 (0.866)	20 (0.787)	19 (0.748)	16 (0.630)	11 (0.433)	8.5 (0.335)	6 (0.236)	80
6	GD01-06-1F	25 (0.984)	23 (0.906)	22 (0.866)	19 (0.748)	14 (0.551)	11.5 (0.453)	9 (0.354)	70
8	GD01-08-1F	31 (1.220)	29 (1.142)	28 (1.102)	25 (0.984)	20 (0.787)	17.5 (0.689)	15 (0.591)	60
10	GD01-10-1F	37 (1.457)	35 (1.378)	34 (1.339)	31 (1.220)	26 (1.024)	23.5 (0.925)	21 (0.827)	50

GD02-□□-1F (Reverse Type)

Unit:mm(inch)

3mm Pitch (Reverse Type)

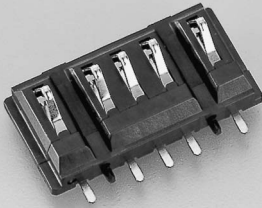

X-X' Cross Section

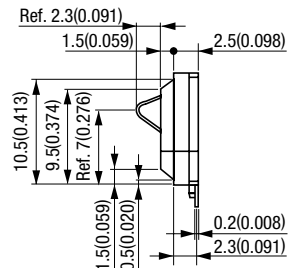
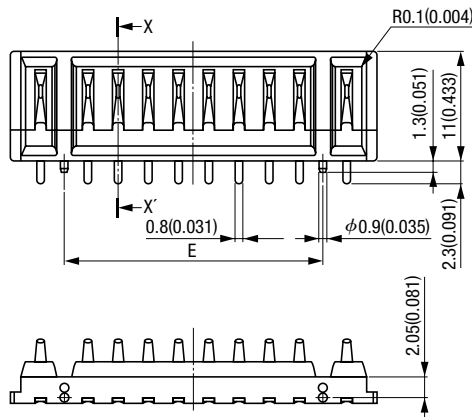
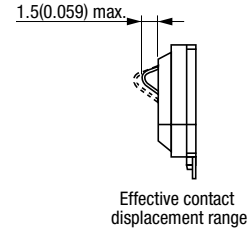
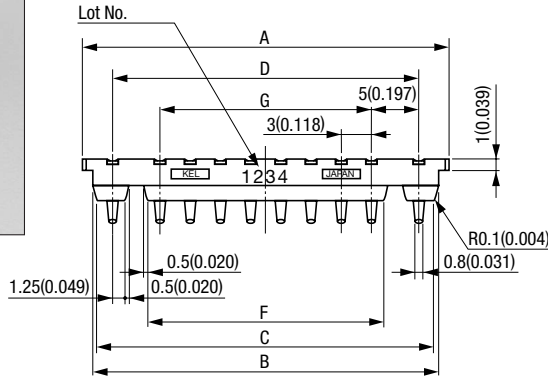
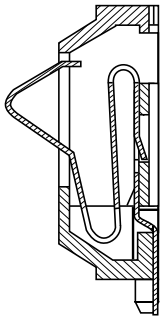

Note: 10 pin connector is shown.

Recommended PCB Layout (Component Side View)

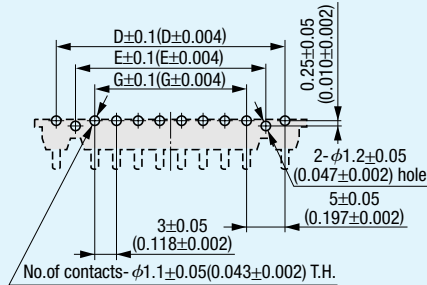

Recommended Dimensions for Battery Terminals

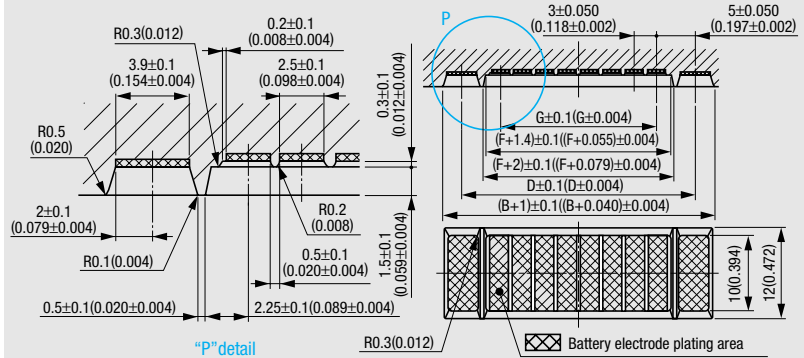

Packaging style
Tray

Product Table / Dimensions

No. of contacts	Part Number	A	B	C	D	E	F	G	Number of packaging
4	GD02-04-1F	19 (0.748)	17 (0.669)	16 (0.630)	13 (0.512)	8 (0.315)	5.5 (0.217)	3 (0.118)	90
5	GD02-05-1F	22 (0.866)	20 (0.787)	19 (0.748)	16 (0.630)	11 (0.433)	8.5 (0.335)	6 (0.236)	80
6	GD02-06-1F	25 (0.984)	23 (0.906)	22 (0.866)	19 (0.748)	14 (0.551)	11.5 (0.453)	9 (0.354)	70
8	GD02-08-1F	31 (1.220)	29 (1.142)	28 (1.102)	25 (0.984)	20 (0.787)	17.5 (0.689)	15 (0.591)	60
10	GD02-10-1F	37 (1.457)	35 (1.378)	34 (1.339)	31 (1.220)	26 (1.024)	23.5 (0.925)	21 (0.827)	50

Fixing Method

Note:

Shown below are the recommended 'Fixing Guides' to protect the PCB and Battery Connector from Stress when inserting/withdrawing the Battery pack.

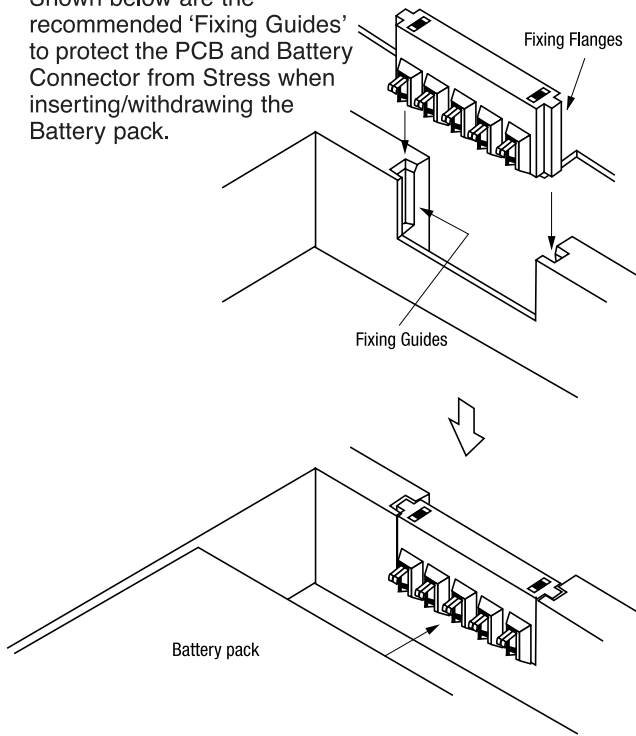

Directions For Battery Pack Insertion/Removal

Horizontal

•Standard (GC11-□□-1F)
(GD01-□□-1F)

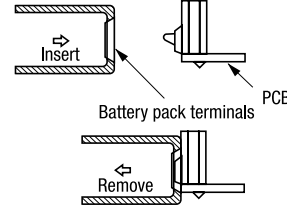

•Reverse (GC02-□□-2F)
(GD02-□□-1F)

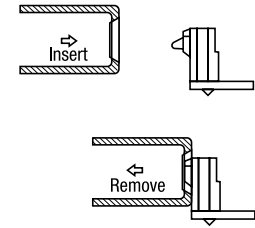

Vertical

•Standard (GC11-□□-1F)
(GD01-□□-1F)

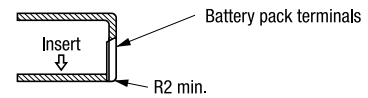

•Reverse (GC02-□□-2F)
(GD02-□□-1F)

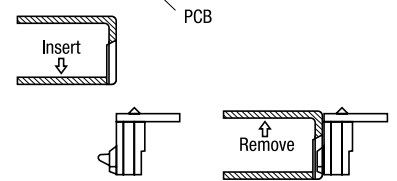

Acceptable range of angles

•Standard (GC11-□□-1F)
(GD01-□□-1F)

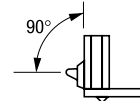

•Reverse (GC02-□□-2F)
(GD02-□□-1F)

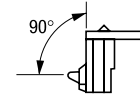

Note:

Please keep your design within the prescribed acceptable range of angles for battery pack insertion/removal, otherwise battery pack or connector will be damaged.

Short-circuit Contact



FEATURES

- Low profile (0.45mm)
- Life is 10,000 cycles
- Gold plating (0.3 μ m) for contact reliability
- Easy hand mounting without tooling
- Can improve safety of the battery pack

SPECIFICATIONS

- Contact material : Copper alloy
- Plating (Contact area) : 0.3 μ m min. Gold over Nickel
- Current rating : DC 3A
- Contact resistance : 30m Ω max.
- Contact force : 1kg max.
- Operating temperature : -55 $^{\circ}$ C to +85 $^{\circ}$ C
- * Specification for Battery electrode : Material ; Nickel

ORDER CODE

064G

- Plating of contact area
G : Au 0.3 μ m (Standard)
- Series name
Short-circuit contact for battery pack

064G

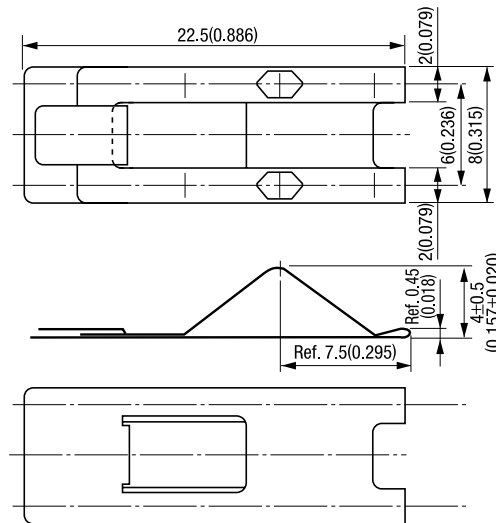

Unit:mm(inch)

Product Table	
Part Number	Number of packaging
064G	500

Packaging style
Other

Recommended Assembly Procedure

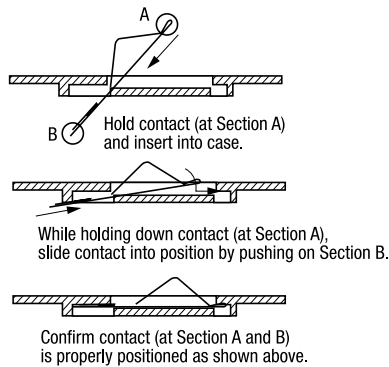

Recommended Panel Layout

